

9/67

PVM-2530

RM-739

SERVICE MANUAL

US Model
Canadian Model
Chassis No. SCC-A58A-A

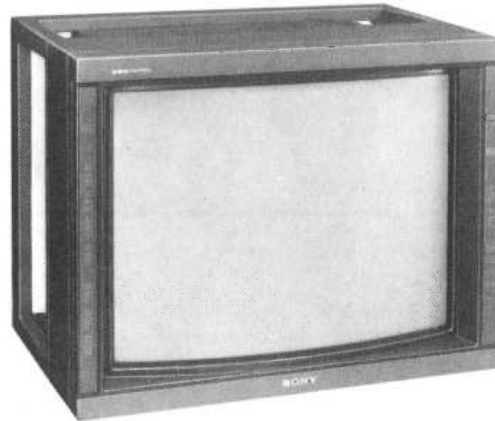

December, 1986

THIS MANUAL CONTAINS
SUPPLEMENTS No. 1 .

SPECIFICATIONS

Note: The service manuals for RM-739
have been issued separately.

Color system NTSC system
 Picture tube Trinitron tube
 Approx. 63.5 cm picture measured diagonally,
 100-degree deflection, AG Pitch 0.73 mm

Resolution VTR inputs: 560 TV lines
 RGB inputs: 640 x 200 dots
 (2000 characters)

Color temperature 9300°K

Frequency response 10 MHz (-3 to +4 dB, RGB)
 6 MHz (+3 dB, composite video)

Horizontal linearity Less than ±5%
 Vertical linearity Less than ±5%
 Line pull range Horizontal: +500 Hz
 Vertical: -8 Hz

Overscan of the picture Less than +7%

Input return loss More than 35 dB up to 4 MHz
 Zooming Within 5%
 Convergence Central area: within 1.0 mm
 Periphery: within 1.8 mm

Inputs
 VIDEO IN: LINE A/B: BNC connector
 composite video, 1 Vp-p ±6 dB, sync negative,
 75-ohms termination switchable
 VTR: 8-pin connector,
 composite video, 1 Vp-p ±6 dB,
 sync negative, 75-ohms terminated

AUDIO IN: LINE A/B: Phono jack,
 -5 dBs, high impedance
 VTR: 8-pin connector, -5 dBs,
 high impedance

CMPTR 25-pin connector (See "Pin assignment")

Outputs
 VIDEO OUT: LINE A/B: BNC connector
 AUDIO OUT: LINE A/B: Phono jack
 SPEAKER: 8 ohms

Power requirements 120 V AC, 50/60 Hz

Power consumption 180 W max

Dimensions Approx. 653 x 508 x 491 mm (w/h/d)
 (25 3/4 x 20 x 19 3/8 inches)

Weight Approx. 53 kg (116 lb 14 oz)

Supplied accessories

Remote commander RM-739, with 2 batteries
 (IEC designation R6) 1
 BNC-Phono adaptor plug..... 4

Optional accessories

SU-539 TV stand
 SU-541 TV stand
 SS-X6A speaker system
 APM-X5A speaker system

T.C. Corp
 10 North Main St
 Wharton NJ 07885
www.servicemanuals.net

TRINITRON COLOR VIDEO MONITOR

SONY®



CMPTR connector (25-pin)

Pin assignment

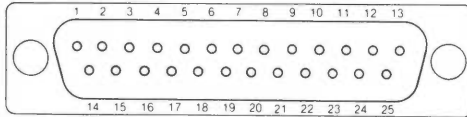

Pin No.	Signal	Signal level
1*	IBM select	High state (5 V): IBM mode Low state: 3 Bit TTL
2	Audio select	High state (5 V or open): Audio inputs from pin 13. Low state (less than 0.4 V): Audio inputs from the LINE A AUDIO IN jacks
3	H. sync or composite sync	Negative polarity When the high state is selected at pin 9: 1 Vp-p, 75-ohm terminated When the low state is selected at pin 9: TTL level
4	Blue input	Positive polarity When the high state is selected at pin 9: Analog signal (0.7 Vp-p, 75-ohm terminated, non sync 1 Vp-p, 75-ohm terminated, with sync on G-signal) When the low state is selected at pin 9: Digital signal (TTL level)
5	Green input	
6	Red input	
7	No connection	—
8		
9*	Analog/digital mode select	High state (open): Analog signal (0.7 Vp-p) Low state (ground): Digital signal (TTL level)
10	RGB/NORMAL mode select	High state (5 V or open): RGB inputs from a microcomputer Low state (ground): Composite video inputs from the LINE A/LINE B VIDEO IN or VTR connector
11	V-sync	Negative polarity TTL level
12	Blanking	High state (5 V or open): Video inputs from a microcomputer only Low state (ground): Composite video input from the LINE A/LINE B VIDEO IN or VTR connector During the low state, the video signal from the microcomputer is blanked and the composite video signal from the LINE A/LINE B VIDEO IN or VTR connector is superimposed over the signal from the microcomputer.
13	Audio input	Input level -5 dB (100% modulation), input impedance more than 47 k ohms
14	No connection	—
15-24	Ground	
25*	IBM luminance signal	Positive polarity When the high state is selected at pin 1: TTL level When the low state is selected at pin 1: Low state (ground)

Design and specifications subject to change without notice.

TROUBLESHOOTING

If these symptoms occur when you begin operation, follow the suggestions below.

SYMPTOMS	CORRECTIONS
No controllable keys although the POWER switch is turned on.	• Press the CONTROL key.
No indication appears although the CONTROL key is pressed.	• Set the MANUAL CONTROL switch on the rear panel to ON.
Remote control is not possible.	• Set the REMOTE CONTROL switch on the rear panel to ON.

If the problem still cannot be solved, contact your authorized Sony dealer.

SAFETY CHECK-OUT (US model only)

After correcting the original service problem, perform the following safety checks before releasing the set to the customer:

1. Check the area of your repair for unsoldered or poorly-soldered connections. Check the entire board surface for solder splashes and bridges.
2. Check the interboard wiring to ensure that no wires are "pinched" or contact high-wattage resistors.
3. Check that all control knobs, shields, covers, ground straps, and mounting hardware have been replaced. Be absolutely certain that you have replaced all the insulators.
4. Look for unauthorized replacement parts, particularly transistors, that were installed during a previous repair. Point them out to the customer and recommend their replacement.
5. Look for parts which, though functioning, show obvious signs of deterioration. Point them out to the customer and recommend their replacement.
6. Check the line cord for cracks and abrasion. Recommend the replacement of any such line cord to the customer.
7. Check the condition of the monopole antenna (if any).
Make sure the end is not broken off, and has the plastic cap on it. Point out the danger of impalement on a broken antenna to the customer, and recommend the antenna's replacement.
8. Check the B+ and HV to see they are at the values specified. Make sure your instruments are accurate; be suspicious of your HV meter if sets always have low HV.
9. Check the antenna terminals, metal trim, "metallized" knobs, screws, and all other exposed metal parts for AC leakage. Check leakage as described below.

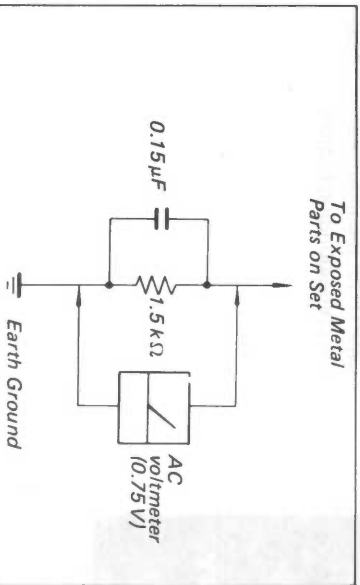

Fig. A. Using an AC voltmeter to check AC leakage.

LEAKAGE TEST

The AC leakage from any exposed metal part to earth ground and from all exposed metal parts to any exposed metal part having a return to chassis, must not exceed 0.5 mA (500 microamperes). Leakage current can be measured by any one of three methods.

1. A commercial leakage tester, such as the Simpson 229 or RCA WT-540A. Follow the manufacturers' instructions to use these instruments.
2. A battery-operated AC milliammeter. The Data Precision 245 digital multimeter is suitable for this job.
3. Measuring the voltage drop across a resistor by means of a VOM or battery-operated AC voltmeter. The "limit" indication is 0.75 V, so analog meters must have an accurate low-voltage scale. The Simpson 250 and Sanwa SH-63Trd are examples of a passive VOM that is suitable. Nearly all battery operated digital multimeters that have a 2 V AC range are suitable. (See Fig. A)

HOW TO FIND A GOOD EARTH GROUND

A cold-water pipe is guaranteed earth ground; the cover-plate retaining screw on most AC outlet boxes is also at earth ground. If the retaining screw is to be used as your earth-ground, verify that it is at ground by measuring the resistance between it and a cold-water pipe with an ohmmeter. The reading should be zero ohms. If a cold-water pipe is not accessible, connect a 60-100 watts trouble light (not a neon lamp) between the hot side of the receptacle and the retaining screw. Try both slots, if necessary, to locate the hot side of the line, the lamp should light at normal brilliance if the screw is at ground potential. (See Fig. B)

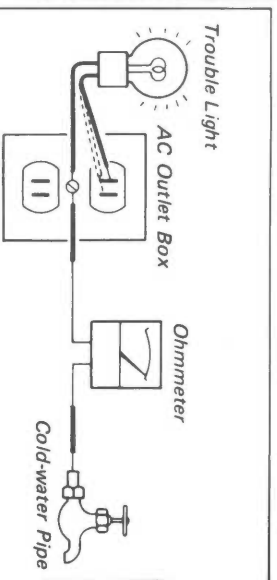

Fig. B. Checking for earth ground.

TABLE OF CONTENTS

Section	Title	Page
1. GENERAL	1-1. Location and Function of Parts and Controls . . .	5
	1-2. System Connections	9
2. DISASSEMBLY	2-1. Picture Tube Removal	14
3. SETUP ADJUSTMENT	3-1. Beam Landing	15
	3-2. Convergence	15
	3-3. Setup Adjustment	17
	3-4. White Balance Adjustment	18
4. SAFETY RELATED ADJUSTMENTS		18, 19
5. CIRCUIT ADJUSTMENT	5-1. D Board Adjustment	19
	5-2. H3 Board Adjustment	23
	5-3. B1 Board Adjustment	24
6. DIAGRAMS	6-1. Circuit Board Location	27
	6-2. Block Diagrams	28
	6-3. Schematic Diagrams (1)	32
	6-4. Printed Wiring Boards (1)	37
	6-5. Schematic Diagrams (2)	42
	6-6. Printed Wiring Boards (2)	47
	6-7. Semiconductors	56
7. EXPLODED VIEWS	7-1. Ct	57
	7-2. Chassis	58
	7-3. Back Cover	59
	7-4. Key Board	60
8. ELECTRICAL PARTS LIST		61
	SUPPLEMENT No. 1	85

SAFETY-RELATED COMPONENT WARNING !!

COMPONENTS IDENTIFIED BY SHADING AND MARK **Δ** ON THE SCHEMATIC DIAGRAMS, EXPLODED VIEWS AND IN THE PARTS LIST ARE CRITICAL TO SAFE OPERATION. REPLACE THESE COMPONENTS WITH SONY PARTS WHOSE PART NUMBERS APPEAR AS SHOWN IN THIS MANUAL OR IN SUPPLEMENTS PUBLISHED BY SONY. CIRCUIT ADJUSTMENTS THAT ARE CRITICAL TO SAFE OPERATION ARE IDENTIFIED IN THIS MANUAL. FOLLOW THESE PROCEDURES WHENEVER CRITICAL COMPONENTS ARE REPLACED OR IMPROPER OPERATION IS SUSPECTED.

ATTENTION AUX COMPOSANTS RELATIFS À LA SÉCURITÉ !!

LES COMPOSANTS IDENTIFIÉS PAR UNE TRAME ET PAR UNE MARQUE **Δ** SUR LES SCHEMAS DE PRINCIPE, LES VUES EXPLODÉES ET LES LISTES DE PIÈCES SONT D'UNE IMPORTANCE CRITIQUE POUR LA SÉCURITÉ DU FONCTIONNEMENT. NE LES REMPLACER QUE PAR DES COMPOSANTS SONY DONT LE NUMÉRO DE PIÈCE EST INDIQUÉ DANS LE PRÉSENT MANUEL OU DANS DES SUPPLÉMENTS PUBLIÉS PAR SONY. LES RÉGLAGES DE CIRCUIT DONT L'IMPORTANCE EST CRITIQUE POUR LA SÉCURITÉ DU FONCTIONNEMENT SONT IDENTIFIÉS DANS LE PRÉSENT MANUEL. SUIVRE CES PROCÉDURES LORS DE CHAQUE REMPLACEMENT DE COMPOSANTS CRITIQUES, OU LORSQU'UN MAUVAIS FONCTIONNEMENT EST SUSPECTÉ.

SECTION 1

GENERAL LOCATION AND FUNCTION OF PARTS AND CONTROLS

Front panel

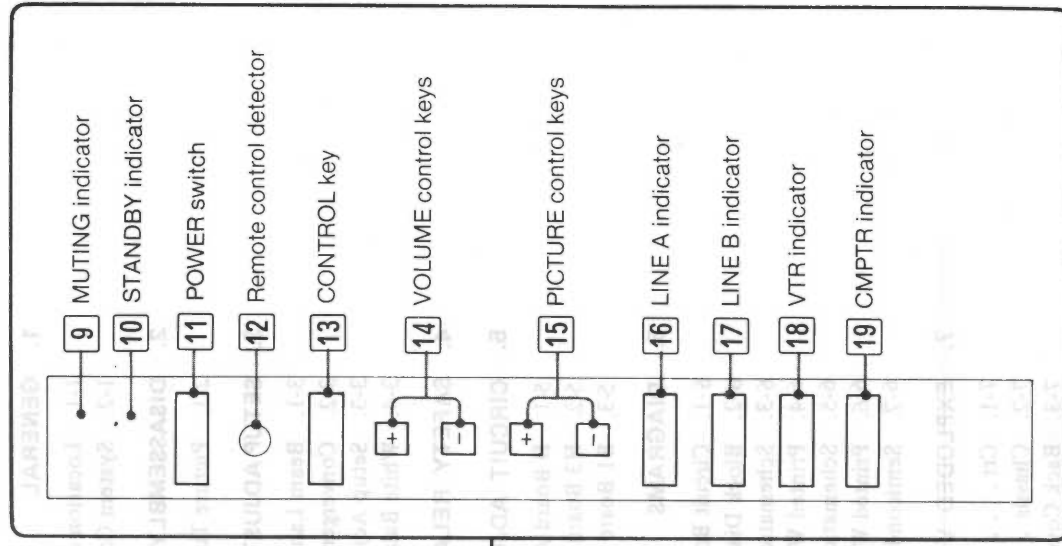
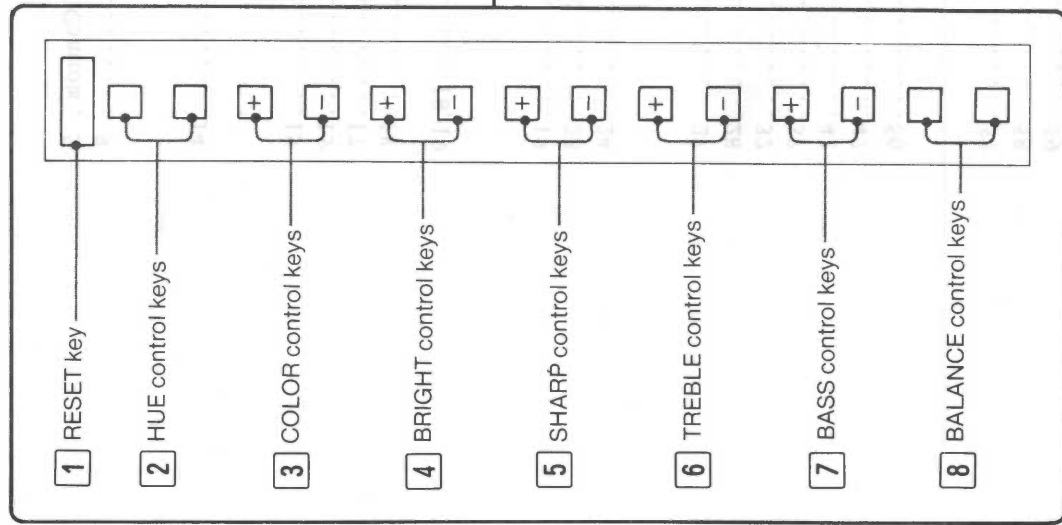

- 9 MUTING indicator**
Illuminates while the sound is muted.
• Muting is controlled only by a remote commander.
- 10 STAND BY indicator**
Illuminates when the POWER switch is turned off.
- 11 POWER switch**
Press this switch to turn the monitor on.
Press this switch again to turn it off.
• When the monitor is turned on, the settings of the monitor are the same as when it was last turned off.
• For a few seconds after turning on the monitor the color of picture may vary because the white balance is adjusted at this time. This is not a problem.
- 12 REMOTE control detector**
The beam from the Remote Commander is received here.
- 13 CONTROL key**
Press this key to illuminate the keys and indicators on the front panel.
Press this key again to extinguish them.

- 14 VOLUME control keys**
Press the + key to raise the volume or the - key to lower it.
- 15 PICTURE control keys**
Press the + key to make the contrast, color intensity and brightness stronger or the - key to make them weaker.

- 16 LINE A indicator**
- 17 LINE B indicator**
- 18 VTR indicator**
- 19 CMPTR (computer) indicator**
When the input source is selected, each indicator:
• Blinks if the indicators and keys excepting input source indicators illuminate.
• Illuminates if they are extinguished.

Key illumination
For the keys **1** through **8**, **14** and **15**:
• While each key is pressed, it blinks, indicating that adjustment is going on.
• During adjustment, if the adjustment value reaches the limit, the blinking speed becomes slower.

Remote commander

- MUTING button**
Press this button to mute the sound.
Press this button again to cancel muting.
• When muting is cancelled, the volume returns to the level before muting.
- LINE A button ****
- CMPTR (computer) button ****
- PICTURE control buttons ***

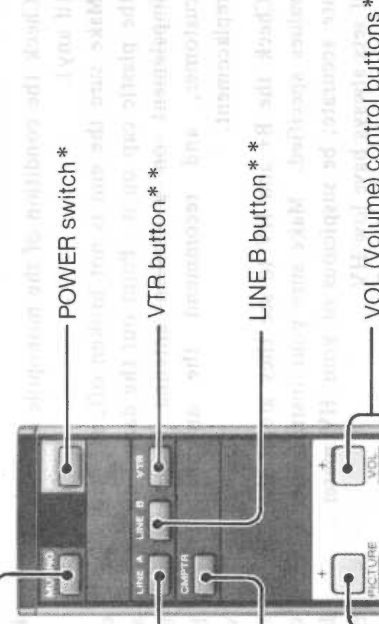

- POWER switch ***
 - VTR button ****
 - LINE B button ****
 - VOL (Volume) control buttons ***
- * The function of these buttons is the same as those on the front panel.
** To select LINE A, LINE B, VTR or CMPTR for the input source, press the corresponding button.

• Press CONTROL key after power is turned on to light the control keys or indicators.

The following control keys are effective only when MANUAL CONTROL switch on the rear panel is set to ON.

- 1 RESET key**
Press this key to return to the standard setting.
• This key is effective only for the control keys on the left.
- 2 HUE control keys**
Press the GRN (green) key to make the skin tones greenish or the PUR (purple) key to make it purplish.
- 3 COLOR control keys**
Press the + key to make the color intensity vivid or the - key to make it pale.
- 4 BRIGHT (brightness) control keys**
Press the + key to make the picture brighter or the - key to make it darker.
- 5 SHARP (sharpness) control keys**
Press the + key to obtain a sharp picture or the - key to obtain a less sharp picture.
- 6 TREBLE control keys**
Press the + key to increase the treble (high tone) or the - key to decrease it.
- 7 BASS control keys**
Press the + key to increase the bass (low tone) or the - key to decrease it.
- 8 BALANCE control keys**
Press the L key to increase the sound volume of the left speaker or the R key to increase the sound volume of the right speaker.